



TriStar® Headset

user's
guide

User's Guide
Guide d'Utilisation
Manual del Usuario
Manual do Usuário

 **PLANTRONICS**

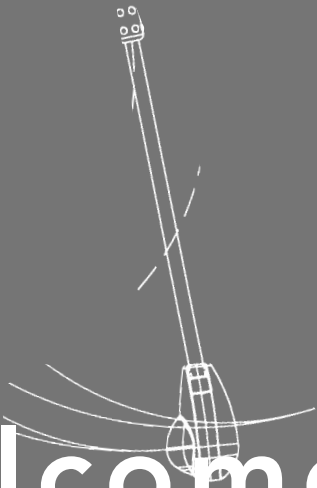

welcome

to hands-free communications from Plantronics

With a TriStar® headset, you will experience a level of comfort and on-the-job freedom that will make your job easier than ever before. Worn on one ear, the TriStar features a unique three-contact support system for a secure fit no matter how much you move around. And it's lightweight for maximum comfort throughout the day.

To help you make the most of the TriStar headset's features, please read the important information contained in this manual. It explains the components and functions of both the Voice Tube and Noise-Canceling models and ways to optimize their performance.

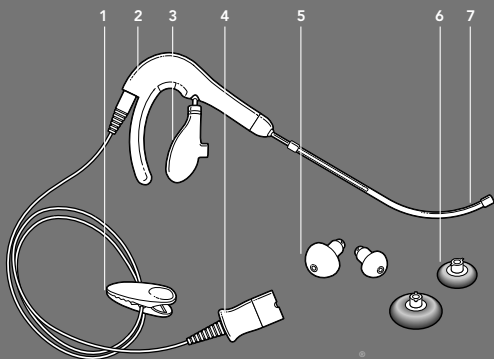

TriStar®
TriStar NC™

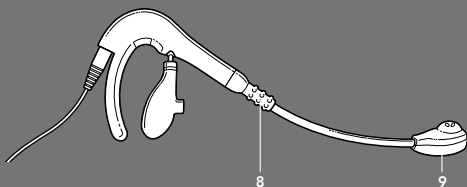

- 6** Small and Large Belltip
Embout cloche petit avec coussinet/Embout cloche gros avec coussinet
Casquillo en campana pequeño/Casquillo en campana grande
Receptor Belltip Pequeno com Espuma/Receptor Belltip Grande com Espuma

- 7** Voice Tube
Tube Micro
Tubo Acústico
Tubo do Microfone

- 8** Boom Grip
Manche de la Perche
Sujetador del Brazo
Ajuste da Extensão
- 9** Noise Canceling Microphone
Microphone antibruit
Micrófono reductor de ruido
Microfone com cancelamento de ruído

1

before
you begin

**BEFORE YOU
BEGIN**

**AVANT DE
COMMENCER**

**ANTES DE
COMENZAR**

**ANTES DE
COMENÇAR**

Tragion

4.02

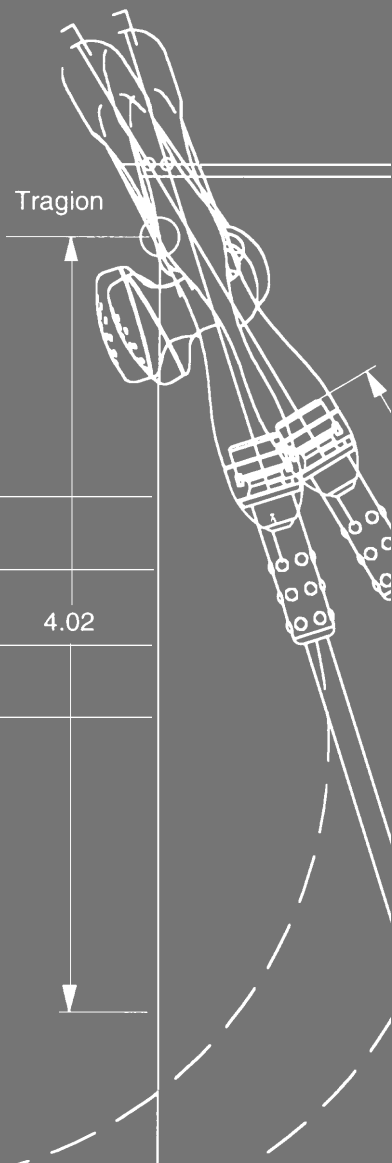

Select one of the four earbuds and insert it into the receiver, aligning the pins with the notches. Rotate the earbud clockwise, $\frac{1}{4}$ turn, until it clicks into place.

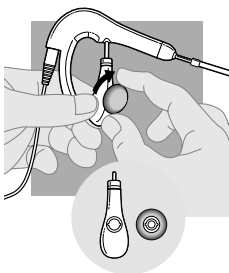

Try all four earbuds until you find one that comfortably rests against, but does not enter, your ear canal.

WARNING

For your safety and comfort, the earpieces should not be inserted into the ear canal.

Never remove the black retention ring from the base of the earpiece or use an earpiece without the retention ring in place.

This headset is not intended for children under the age of 14 and can be dangerous and harmful to younger children. Some parts of this headset are small enough to be swallowed or to become lodged in a child's windpipe, ears or nose. In addition, this headset, as with any product with long strings or cords, may be dangerous for infants and young children as the cords may become wrapped around a child's neck, causing strangulation. To avoid danger of suffocation, keep the plastic bags in which this product is wrapped away from babies and children. Do not use the bags in cribs, beds, carriages or playpens. The plastic bags could block the nose and mouth and prevent breathing.

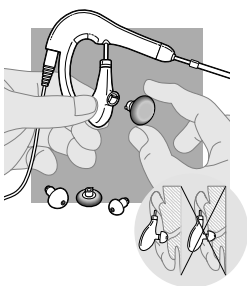

2

adjusting the ear piece

**ADJUSTING THE
EAR PIECE**

**RÉGLAGE DE
L'ÉCOUTEUR**

**AJUSTE DE LA
OREJERA**

**AJUSTE DA PEÇA
AURICULAR**

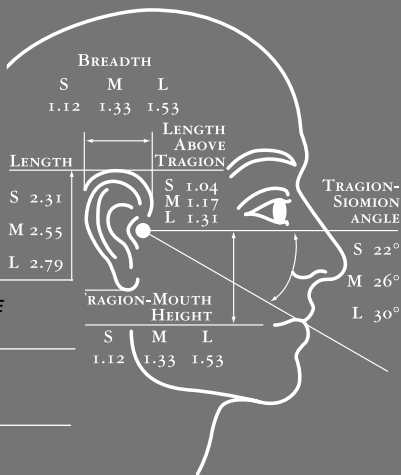

ADJUSTING THE EAR PIECE

Grasp the earloop and move the receiver housing out as far as possible.

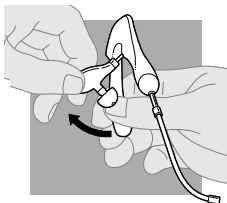

Place the earloop above and slightly in front of your ear and rotate down and back.

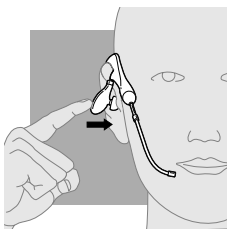

Adjust the receiver arm up and down and side to side until the earbud is comfortably positioned in your outer ear.

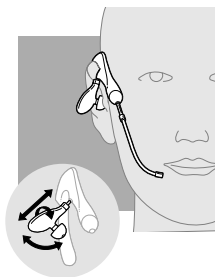

3

adjusting the mouth piece

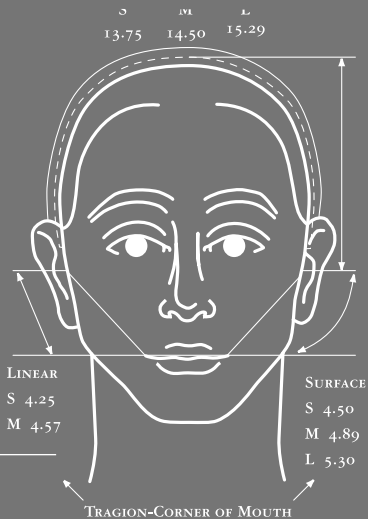

**ADJUSTING THE
MOUTH PIECE**

**RÉGLAGE DU
TUBE MICRO**

**AJUSTE DEL TUBO
ACÚSTICO**

**AJUSTE DO TUBO
DE VOZ**

Standard Models

Hold the receiver securely against your ear with one hand.

With your other hand, adjust the voice tube so that the tip sits two finger-widths from the corner of your mouth. To prevent breath noise, avoid positioning the voice tube in front of your mouth.

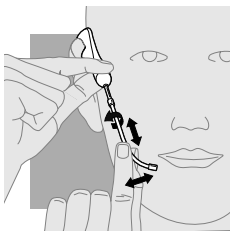

Noise-Canceling Models

Carefully shape the boom with both hands as shown. Do not bend or twist the boom within $\frac{1}{2}$ inch of the microphone.

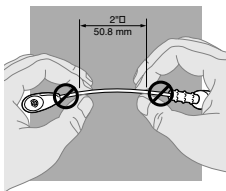

Position the boom so that the microphone sits two finger-widths from the corner of your mouth.

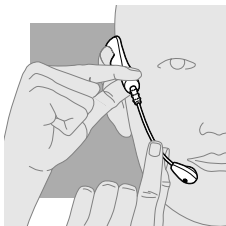

Make sure the front of the microphone faces your mouth. If necessary, carefully rotate the microphone into the proper position. Avoid repeated twisting of the boom.

To temporarily move the Noise-Canceling microphone boom away from your mouth, rotate the boom grip. To return the boom to its original position, reverse the rotation.

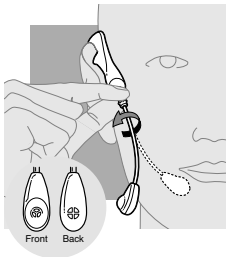

4

Polaris™ models and additional features

**POLARIS™
MODELS
ADDITIONAL
FEATURES**

**CASQUES DE
MODÈLE POLARIS
FONCTIONS
ADDITIONNELLES**

**MODELOS DE
AUDÍFONOS
POLARIS
CARACTERÍSTICAS
ADICIONALES**

**MODELOS DE
FONES DE OUVIDO
POLARIS
RECURSOS
ADICIONAIS**

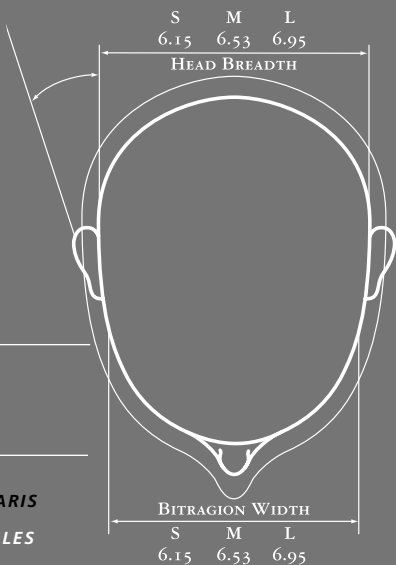

Polaris™ Headset Models

The Polaris headset model is fitted with a standard modular connector.

To use the Polaris headset model, simply insert the modular connector into the headset receptacle of a compatible telephone.

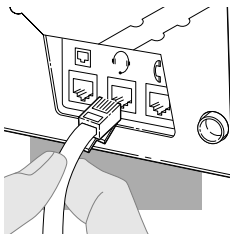

Clothing Clip

The clothing clip keeps the headset properly seated and free from the cord's weight. Attach the clothing clip at a comfortable level.

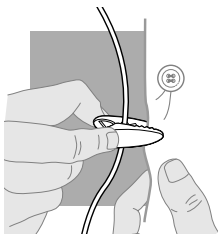

Quick Disconnect™ Connector

Some headset models are equipped with a Quick Disconnect connector. This feature allows you to place a call on hold and move away from the phone without removing the headset. When you separate the Quick Disconnect, you place an ongoing conversation on hold.

Before using your headset, join the Quick Disconnect to the mating connector of a plug prong, modular, or Polaris adapter cable.

To put your call on hold, grasp Quick Disconnect, as shown, and pull straight apart.

To resume your conversation, reconnect the two halves.

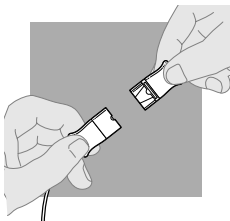

5

maintenance and trouble shooting

**MAINTENANCE HINTS FOR
OPTIMUM PERFORMANCE
TROUBLE SHOOTING GUIDE**

**CONSEILS D'ENTERTIEN
POUR UNE PERFORMACE
OPTIMALE
GUIDE DE DÉPANNAGE**

**CONSEJOS DE
MANTENIMIENTO TÉCNICO
PARA OBTENER UN
RENDIMIENTO ÓPTIMO
INVESTIGACIÓN Y
CORRECCIÓN DE AVERÍAS**

**DICAS DE MANUTENÇÃO
PARA UM DESEMPENHO
SUPERIOR
GUIA PARA A RESOLUÇÃO
DE PROBLEMAS**

Tragion

4.02

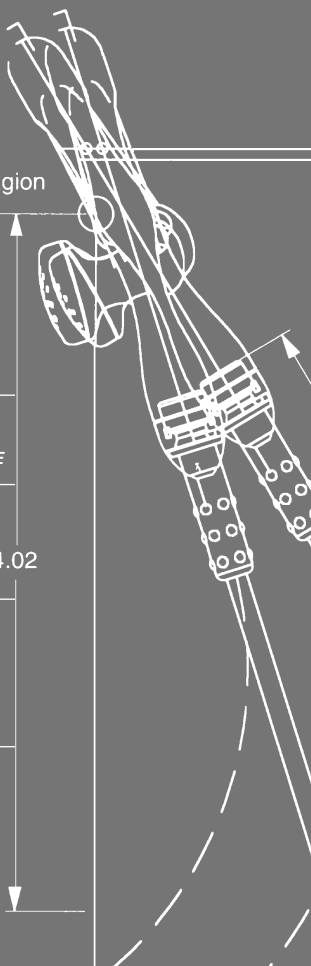

Maintenance Hints for Optimum Performance

- Replace voice tubes every six months
- Replace earbuds every six months
- Clean cable with a moist cloth once a month

Trouble Shooting Guide

PROBLEM	ITEMS TO CHECK
Callers cannot hear me	<p>For voice tube models, determine if the voice tube is clogged or positioned improperly. Plantronics recommends replacing the voice tube every 6 months.</p> <p><i>(For a temporary solution to a clogged voice tube, gently rinse warm water through the voice tube for a minute then manually swing or shake it dry. Make sure the voice tube is completely dry before reattaching.)</i></p> <p>For Noise-Canceling models, make sure the microphone is facing your mouth and positioned properly.</p> <p>If you have a modular adapter, verify that the transmit volume control is set properly.</p>
I cannot hear callers	<p>Verify that the Quick Disconnect™ is connected.</p> <p>Make sure the earbud is positioned properly.</p> <p>Make sure the plug prong or modular adapter is installed correctly.</p> <p>Turn up the volume control on the plug prong or modular adapter.</p>
Earpiece is uncomfortable	<p>Determine if the earloop is properly positioned on your ear.</p> <p>Try other earbuds for optimal fit.</p> <p>Try all possible adjustments for the receiver arm (side to side, up and down, in and out).</p>

LIMITED WARRANTY

for Plantronics Commercial Products Purchased in the US and Canada

- This warranty covers defects in materials and workmanship of Commercial Products manufactured, sold or certified by Plantronics which were purchased and used in the United States and Canada.
- This warranty lasts for two years from the date of purchase of the Products.
- This warranty extends to you only if you are the end user with the original purchase receipt.
- We will, at our option, repair or replace the Products that do not conform to the warranty. We may use functionally equivalent reconditioned/refurbished/ remanufactured/pre-owned or new Products or parts.
- To obtain service in the U.S. contact Plantronics at (800) 544-4660 and in Canada call (800) 540-8363. If you need additional information, please contact our service centers at the numbers provided.
- THIS IS PLANTRONICS' COMPLETE WARRANTY FOR THE PRODUCTS.
- This warranty gives you specific legal rights, and you may also have other rights which vary from state to state or province to province. Please contact your dealer or our service center for the full details of our limited warranty, including items not covered by this limited warranty.



© 1995 – 2005 Plantronics, Inc.
All rights reserved. Plantronics,
the logo design, Plantronics and
the logo design combined,
Polaris, Quick Disconnect, and
TriStar are trademarks or
registered trademarks of
Plantronics, Inc.

Patents U.S. 5,259,780;
5,761,298; D375,959; D379,990;
Canada 78200;
China 95,319,003X;
Germany M95,085,572;
GB Regd.Des.No. 2051588;
Japan 971359

Printed in U.S.A. 68915-01
(02•05)

3 4 5 E n c i n a l S t r e e t

S a n t a C r u z

C A 9 5 0 6 0

T e l 8 0 0 5 4 4 . 4 6 6 0

 **PLANTRONICS**